

# talent™

SOUND & LIGHTING

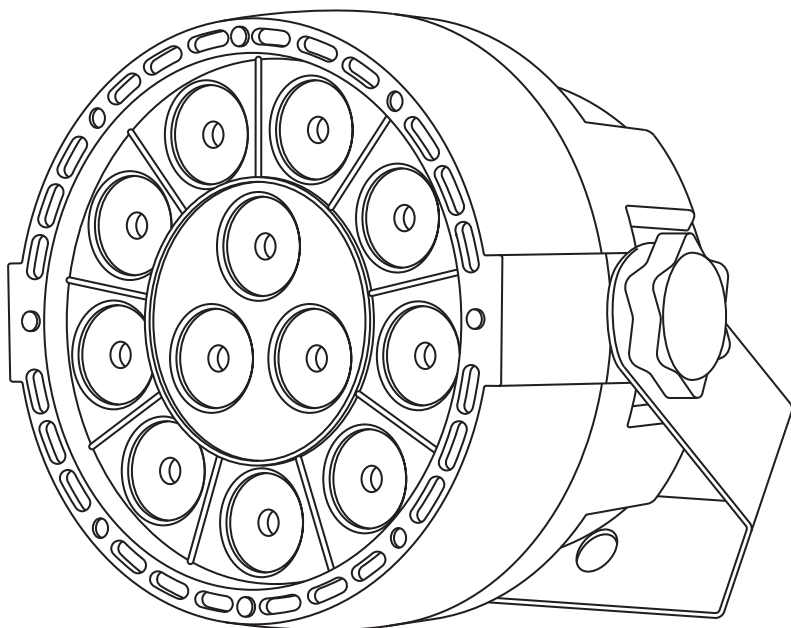

**Mini Par 12 DMX 12x1W LED Light**

**Model: MP12**

**User Manual**

[www.talentaudio.com](http://www.talentaudio.com)

# TABLE OF CONTENTS

1. Safety Instructions	7. Button Specifications
2. Technical Specifications	8. Operating Modes
3. Installation	9. DMX512 Channel Forms
4. How to Connect the Fixture	10. Troubleshooting
5. DMX512 Connections	11. DMX General Information
6. Control Panel	

## 1. Safety Instructions

- Please keep this User Manual for future consultation. If you sell the fixture, be sure to include this instruction booklet to ensure proper maintenance and use.
- Unpack and check carefully for transportation damage before using the fixture.
- Before operating, ensure that the power supply voltage and frequency match the power of your electrical system.
- Disconnect main power before servicing and maintenance.
- Use a safety cable when permanently mounting this fixture. Always handle the fixture with care.
- Maximum ambient temperature is 104° F.
- In the event of a serious operating problem, stop using the fixture immediately. Please contact the dealer from whom you purchased the fixture, the nearest authorized technical repair facility, or Talent Sound & Lighting directly.
- Do not connect the device to any dimmer pack.
- Do not touch exposed wires during use, as there might be a hazard of electrical shock.
- To prevent or reduce the risk of electrical shock or fire, do not expose the fixture to rain or moisture. Its rating is IP20, for indoor use only.
- The fixture must be replaced if there is visible damage to the housing.
- Do not look directly at the LED light beam while the fixture is on.

**Warning:** Please read the instructions carefully. They include important information about installation, operation, and maintenance. Do not connect more than 32 units in series (daisy-chaining) on a single power circuit.

**Caution:** There are no user serviceable parts inside the fixture. Do not open the housing or attempt any repairs yourself. In the unlikely situation your unit may require service, please contact your dealer or Talent Sound & Lighting.

## 2. Technical Specifications

- DMX channels: 7
- 12x Ultra Bright 1 watt LEDs (Red: 3, Green: 3, Blue: 3, White: 3)
- Static Colors/Dimmer/Strobe/Fade/Jump
- Auto, sound active, DMX, and master/slave modes
- Internal programs with sound activation
- 3-pin XLR in/out sockets for DMX control
- RGBW color mixing
- Beam angle: 25°
- Power consumption: 15 watts
- Power input: AC 110V-240V 50-60 Hz
- Dimensions: 120.5 mm diameter x 89.2 mm deep, 141.5 mm knob-to-knob, 150.5 mm from fixture to yoke
- Weight: 0.5 Kg

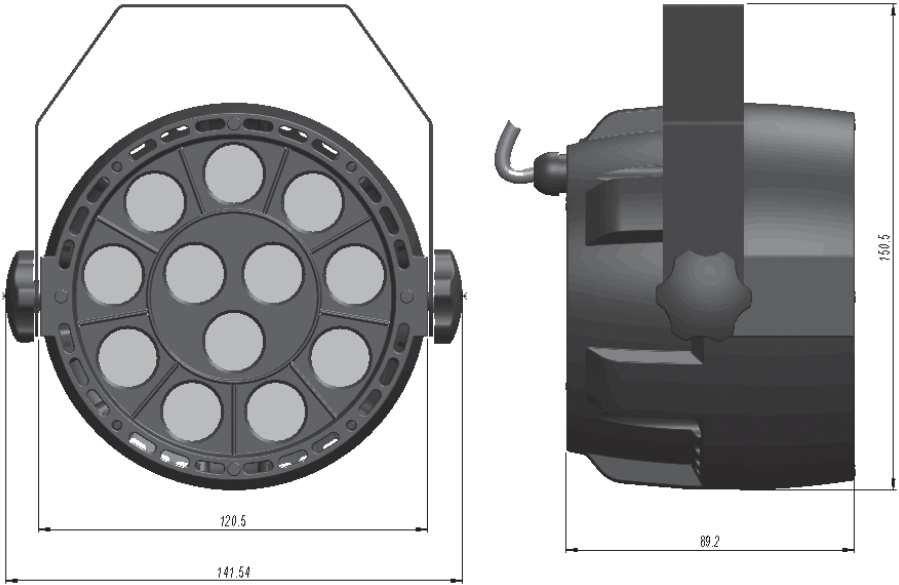

### 3. Installation

The unit should be mounted via its screw holes on its bracket. Always ensure that the unit is installed to avoid vibration while operating. Always ensure that the structure to which you are attaching the unit is secure and is able to support a weight of 10x this fixture's weight. Always use a safety cable that can hold 12x the weight of the fixture.

### 4. How to Connect the Fixture

#### 3-Pin and 5-Pin XLR DMX Connectors:

Some manufactures use 5-pin XLR connectors for data transmission in place of 3-pin. 5-pin XLR fixtures may be implemented in a 3-pin XLR DMX line. When inserting standard 5-pin XLR connectors into a 3-pin line, a cable adapter must be used. The chart below details the correct cable conversion.

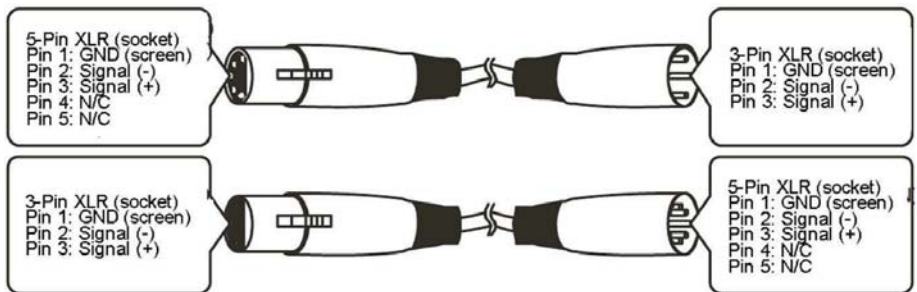

## 5. DMX512 Connections

DMX512 is a widely used protocol for intelligent lighting control, with 512 available channels. Even if you do not wish to operate your Talent lighting fixture via an outboard DMX controller, utilizing the master/slave mode will still require unit-to-unit connection by proper DMX cables.

**Caution:** Common microphone cables may be used to connect small numbers of DMX fixtures over short distances, but offer the risk of erratic operation. Use of correct DMX cables greatly reduces data errors caused by improper connection.

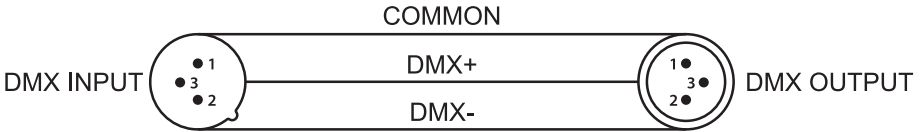

- If you are using a controller with 5-pin DMX output, use a 5-pin to 3-pin adapter cable.
- Connect fixtures together in a “daisy chain” by connecting the DMX output of the first fixture to the DMX input of the next fixture. This cable cannot be branched or split by a “Y” cable. Inadequate or damaged cables, bad solder joints, or corroded connectors can easily distort the signal, cause errors, and shut down the system. Never allow contact between the data common/shield connection (XLR Pin 1) and the fixture’s chassis/electrical ground.
- The DMX output and input connectors are pass-through to maintain the DMX circuit if power to one of the units is disconnected.
- On the last fixture, the DMX output should be terminated with a terminator to reduce signal errors. Solder a 120 ohm 1/4 watt resistor between pin 2 (DMX-) and pin 3 (DMX+) on a 3-pin XLR plug and connect it to the DMX output of the last fixture.

Termination reduces signal errors and to avoid signal transmission problems and interference. It is always advisable to connect a DMX terminal. (Resistance 120 ohm 1/4W) between pin 2 (DMX-) and pin 3 (DMX+) of the last fixture.



## 6. Control Panel

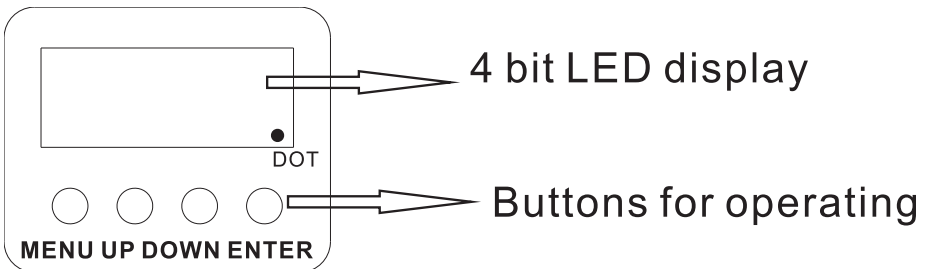

## 7. Button Specifications

Your Talent Sound & Lighting fixture may be operated as a stand-alone device that runs on pre-programmed routines or sound activation, in Master/Slave mode with other devices, or via an external DMX512 controller. In DMX mode it is controlled by 7 channels.

Besides stand-alone operation, there are two main ways to control the fixture:

- A. Universal DMX control mode
- B. Master/Slave operation

Menu Display			
	Up/Down		Function
d001	<----->	d512	DMX address (NOTE: d001 = Slave mode for Master/Slave function)
P000	<----->	P255	Jump change, from slow to fast
L000	<----->	L255	Gradual fade from one color to another, from slow to fast
E000	<----->	E255	Gradual fade from one color to OFF, then fade into another color, from slow to fast
SoUd	n/a		Sound activated mode
r000	<----->	r255	Red, from OFF to full brightness
G000	<----->	G255	Green, from OFF to full brightness
b000	<----->	b255	Blue, from OFF to full brightness
U000	<----->	u255	White, from OFF to full brightness
F000	<----->	F255	Strobe, speed from slow to fast (F000 = full ON)

## 8. Operating Modes

### 8A. Universal DMX controller

This fixture's DMX address can be set remotely by a universal DMX controller. First, you need to program two scenes into a chase, and then link the fixtures to the universal DMX controller. When you run the chase, the fixtures in the chain will set the series DMX address automatically. Each lighting fixture needs to have an address set when in DMX mode, to receive the data sent by the controller. The address number is between 0-511 (usually 0 & 1 are equal to 1).

### 8B. Master/Slave operation

The fixture allows you to link as many as 16 fixtures together and operate without a controller. In Master/Slave mode, the first fixture will control the others to give an automatic synchronized light show. The first, or Master's DMX input will have nothing connected to it. Its output connects to the slave fixtures, which will be set in Slave mode (d001) automatically.

## 9. DMX Channel Structure

Channel	Value	Description
CH1	0-255	Master dimming, OFF to full brightness
CH2	0-255	RED dimming, OFF to full brightness
CH3	0-255	GREEN dimming, OFF to full brightness
CH4	0-255	BLUE dimming, OFF to full brightness
CH5	0-255	WHITE dimming, OFF to full brightness
CH6	0-255	Function select - 0-50 strobe and linear dimming; 51-100 transition; 101-150 gradient change; 151-200 jump change; 201-255 sound active
CH7	0-255	Sets the speed of CH6 function, from slow to fast

For additional details about DMX operation, please review DMX General Information.

## 10. Troubleshooting

Here are some troubleshooting suggestions:

### A. The fixture does not work, there is no light output.

- 1.) Check the connection of power and main fuse.
- 2.) Measure the voltage output on your power receptacle to ensure proper voltage.

### B. Fixture does not respond to DMX control.

- 1.) DMX LED should be on. If not, check DMX connectors and cables for proper connection.
- 2.) If DMX LED is on but not responding to a channel, check the DMX address settings and DMX polarity.
- 3.) If you have intermittent DMX signal problems, check the pins on the cable connectors and on the fixture.
- 4.) Try to use a different DMX controller.
- 5.) Interference may occur if DMX cables are run alongside high voltage cables.

### C. Fixture responds erratically to DMX control.

- 1.) You may have a break in the DMX cabling. Check the LED for the response of the master/ slave mode signal.
- 2.) Wrong DMX address in the fixture. Set the fixture to the proper address.
- 3.) Use of microphone cables for DMX connections can cause errors

### D. The fixture doesn't respond to sound.

- 1.) Make sure the fixture is not set to receive a DMX signal.
- 2.) Check the fixture's internal microphone by tapping the microphone.

## 11. DMX General Information

The DMX512 digital communication protocol was introduced to control stage lighting and special effects.

The DMX standard features 512 available channels, and they are assignable in any sequence that conforms to the user's needs. Each DMX-capable fixture requires one or more sequential channels. A starting address, which indicates the first control channel reserved for that particular fixture, must be assigned to the fixture before the controller can recognize it. DMX controllable fixtures may vary in the number of channels they require, depending on the fixtures features and/or functionality.

Channels should never be permitted to overlap; otherwise, for example, a fader that controls blue output on one fixture may cause strobing or dimming on an adjacent, incorrectly assigned fixture. Multiple fixtures of the same type that use an identical starting address will function in unison. Fixtures assigned properly spaced starting addresses will operate individually, but a DMX controller with sufficient channels can be configured to run these same fixtures either combined or independently.

The sequence in which DMX fixtures are connected has no effect on how a controller communicates with each individual lighting fixture. Although 3-pin XLR mic cables may be used to connect DMX fixtures over short runs, longer distances will introduce data errors due to the mic cable's incorrect impedance. For best results, Talent Sound & Lighting recommends the use of correct 120 ohm, low-capacitance, twisted pair cable designed for the DMX512 protocol. It is also suggested that a termination resistor plug be used on the output connector of the last fixture in an array of DMX instruments. This resistance ensures proper data transmission.

#### WARRANTY COVERAGE

Talent Sound & Lighting products are warranted to be free of all defects in material and workmanship for 5 YEARS from the date of purchase from an authorized Talent Sound & Lighting dealer. This warranty and all rights provided are limited to the original owner and are non-transferable. Talent Sound & Lighting's responsibility is limited to replacement or repair as set forth in this warranty statement.

Should a product require warranty service during this period, Talent Sound & Lighting will repair or replace without charge, any part or product proving defective in material or workmanship. All warranty repairs and service must be performed by an authorized Talent Sound & Lighting technician or service facility. The use of non-authorized repair services renders this warranty null and void, and any charges relating to non-authorized repair are the responsibility of the product owner.

All expenses related to replacing or repairing a defective part or product under this warranty shall be assumed by Talent Sound & Lighting. Talent Sound & Lighting reserves the right to replace defective product with a new or factory reconditioned unit.

#### WARRANTY EXCLUSIONS

1. This warranty does not cover product failure or damage resulting from misuse, abuse, neglect, accidents, alterations, standard environmental deterioration, natural disasters, or improper use and/or installation.
2. This warranty does not cover cosmetic damage due to misuse or neglect. This includes paint damage, scratches, cracks or other superficial marks related to improper use.
3. Failures arising from attempted servicing of a non-authorized Talent Sound & Lighting repair facility or technician are excluded from this warranty.

#### LIMITATION OF DAMAGES

In no event shall Talent Sound & Lighting be liable for consequential damages for breach of this warranty including installation charges, excessive shipping expenses, property loss or other incidental loss. Some States do not allow the exclusion or limitation of incidental or consequential damages, so the above limitation or exclusion may not apply to the buyer.

#### HOW TO OBTAIN WARRANTY SERVICE

To obtain services under this warranty, the buyer shall contact Talent Sound & Lighting's authorized service provider, Parts Express, at 1-800-338-0531 x 780 to obtain a return authorization number (RA#).

The buyer must carefully pack the warranted product along with a copy of the original purchase receipt, the return authorization number (RA#), and a description to the repair facility listed below. Shipping for warranty service is dependent upon the return policy where the Talent Sound & Lighting product was purchased.

Parts Express

Attn: Talent Sound & Lighting Warranty Repairs RA# (please write your RA# here)

725 Pleasant Valley Drive  
Springboro, Ohio 45066

#### NOTICE TO BUYER

This warranty gives you specific legal rights, and you may also have other rights which vary from state to state.



[www.talentaudio.com](http://www.talentaudio.com)